

THE ELEMENTS FOR ACQUIRING THE PRODUCT(S) DESCRIBED HEREIN SHALL CONSIST OF THE SPECIFICATION SHEET AND THE ISSUE OF THE FOLLOWING SPECIFICATION LISTED IN THAT ISSUE OF THE DODISS SPECIFIED IN THE SOLICITATION NONE

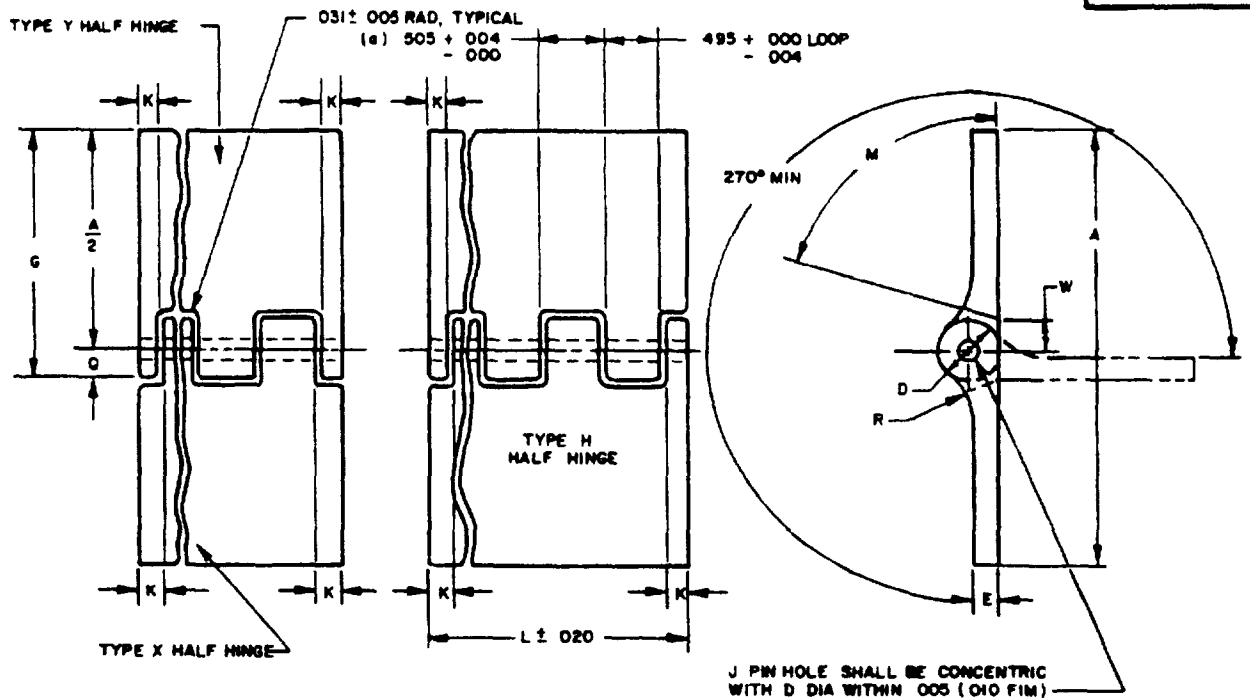

TABLE I.

DASH NO.	A REF WIDTH OPEN	E		G		Q ±.005	J DIA +.005 - .000	(b) K MIN	D DIA		R ±.031 RAD	W ±.016	PIN DIA REF	M ±2°	
		MAX	MIN	MAX	MIN				MAX	MIN					
-2	1.062			.630	.612										
-3	1.250			.724	.706										
-4	1.500	.056	.044	.850	.830	.090	.093	188	.187	.173	.174	.135	.090	75°	
-5	1.750			.975	.955										
-6	2.000			1.102	1.078										
-8	2.000	.076	.064	1.167	1.143	.155	.183			.318	.302	.297	.200		.180
-9	2.500	.056	.044	1.352	1.328					.187	.173	.174	.135		.090
-10	2.750			1.477	1.453	.090	.093								
-12	3.375	.115	.103	1.860	1.828	.156			.370	.304	.375	.188		60°	
-14	3.719	.163	.149	2.086	2.038	.203	.133		.414	.398	.625	.240	.130	45°	
-16	3.938	.210	.196	2.243	2.195	.250	.183		.509	.491	.750	.287	.180		
*-17	1.820	.056	.044	1.180	1.070	.090	.093		.187	.173	.174	.135	.090	75°	

\* CANCELLED - NO SUPERSEDING PART NUMBER

(a) TOLERANCES FOR DIMENSIONS ON PITCH SHALL NOT BE CUMULATIVE  
(b) DIMENSION K MUST NEVER EXCEED A FULL LOOP OR TANG, AND BOTH ENDS MUST BE EQUAL WITHIN .020 INCH

INTERCHANGEABILITY RELATIONSHIP  
MS20001 HINGES ARE NOT UNIVERSALLY INTERCHANGEABLE WITH AN252 HINGES FOR INTERCHANGEABILITY RELATIONSHIP SEE TABLE II

TABLE II

INTERCHANGEABILITY TABLE		
INACTIVE AND CANCELLED	UNIVERSALLY INTERCHANGEABLE	REPLACEABLE WITH
AN252-1	-----	-----
AN252-2	MS20001-2	-----
AN252-4	MS20001-4	-----
AN252-6	MS20001-6	-----
AN252-8	MS20001-8	-----
AN252-10	MS20001-10	-----

(L) DENOTES CHANGES

THIS SPECIFICATION IS APPROVED FOR USE BY ALL DEPARTMENTS AND AGENCIES OF THE DEPARTMENT OF DEFENSE

PREPARING ACTIVITY NAVY - AS CUSTODIANS ARMY - AV NAVY - AIR FORCE - 99 DLA - REVIEW DLA - IS USER PROJECT NUMBER 5347-1084	MILITARY SPECIFICATION SHEET TITLE HINGE, BUTT, STRUCTURAL, EYFLEDED	SPECIFICATION SHEET NUMBER <b>MS20001L 30 OCT 1989</b> SUPERSEDING MS20001Y 30 AUG 1985 AMSC - N/A FSC 5340
DISTRIBUTION STATEMENT A Approved for public release distribution is unlimited		Page 1 of 1

REQUIREMENTS

- 1 MATERIAL ALUMINUM ALLOY 2024-T3511, PER QQ-A-200/3, OR ALUMINUM ALLOY 7075-T73511, PER QQ-A-200/11 (SEE PART NUMBERING).
- 2 FINISH ANODIZE IN ACCORDANCE WITH MIL-A-8625, TYPE II, CHEMICAL SURFACE TREAT IN ACCORDANCE WITH MIL-C-5541, (ENDS OF ALL HINGES SHALL BE FINISHED)
- 3 MARKING INK STAMP MS20001 (DASH NUMBER) REGULAR INTERVALS ALONG LENGTH OF HINGE SO THAT ANY THREE INCH LENGTH WILL HAVE AT LEAST ONE COMPLETE IDENTIFICATION IN FIGURES NOT LESS THAN .060 INCHES HIGH. SEE NOTE 5
4. COMPLETE HINGES SHALL BE FURNISHED AS AN ASSEMBLY WITH CAD PLATED CRES HINGE PINS OF THE SAME LENGTH IN ACCORDANCE WITH MS20253 ~~UNLESS TITANIUM HINGE PINS IN ACCORDANCE WITH MS20253 ARE SPECIFIED (SEE PART NUMBERING).~~
5. DESIGNATION FOR ANODIZING, CHEMICAL SURFACE TREATMENT, HINGE STYLE, AND LENGTH SHALL NOT BE INCLUDED IN MARKING
- 6 ONLY COMPLETE HINGES TO BE STOCKED BY SERVICES.
- 7 USE MS20257 HINGE WHEREVER LOAD REQUIREMENTS PERMIT

NOTES

1. DIMENSIONS ARE IN INCHES.
- 2 REMOVE ALL BURRS AND SHARP EDGES
- 3 TYPE X HALF HINGE MATES WITH TYPE Y HALF HINGE, AS SHOWN
4. TYPE H HALF HINGE MATES WITH TYPE H HALF HINGE
- 5 FOR SERVICE PROCUREMENT, THE PREFERRED STOCK LENGTH OF COMPLETE HINGES IS 72 INCHES
6. PART NUMBERING (NOMENCLATURE TO BE INCLUDED ON SHIPPING DOCUMENTS ONLY)  
PART NUMBERING SHALL CONSIST OF THE FOLLOWING (IN SEQUENCE)
  - a. MS20001
  - b "P" FOR ANODIZED FINISH, "C" FOR CHEMICAL SURFACE TREATMENT, OMISSION OF CODE LETTER WILL INDICATE BARE FINISH
  - c. "H", "X", OR "Y" TO DESIGNATE HALF HINGE STYLE, OMISSION OF CODE LETTER WILL INDICATE COMPLETE HINGE.
  - d "A" FOR 7075-T73511 ALUMINUM ALLOY HINGE, OMISSION OF "A" WILL INDICATE 2024-T3511 ALUMINUM ALLOY.
  - e. ~~"T" FOR TITANIUM HINGE PIN (FOR COMPLETE HINGE ONLY); OMISSION OF "T" WILL INDICATE CADMIUM PLATED CRES HINGE PIN.~~
  - f. DASH NUMBER (TABLE I), OMIT DASH IF PRECEDED BY CODE LETTER
  - g A DASH FOLLOWED BY LENGTH "L" EXPRESSED IN INCHES AND HUNDREDTHS
- 7 EXAMPLES OF PART NUMBERS  
MS20001-4-1200 = COMPLETE HINGE, BARE FINISH, ALUMINUM 2024-T3511, CAD PLATED CRES HINGE PIN, 1 500 INCHES WIDE, 12.00 INCHES LONG.  
 (L) MS20001CHAA-900 = TYPE H HALF HINGE, CHEMICAL SURFACE TREATMENT, ALUMINUM 7075-T73511, 1.500 INCHES WIDE, 9.00 INCHES LONG
- 8 DO NOT SPECIFY "P" FOR ANODIZE IF HINGE IS TO BE SPOTWELDED.
- 9 REFERENCED DOCUMENTS SHALL BE OF THE ISSUE IN EFFECT ON DATE OF INVITATION FOR BIDS, OR REQUEST FOR PROPOSAL EXCEPT THAT REFERENCED ADOPTED INDUSTRY DOCUMENTS SHALL GIVE THE DATE OF THE ISSUE ADOPTED
10. FOR DESIGN FEATURE PURPOSES, THIS STANDARD TAKES PRECEDENCE OVER PROCUREMENT DOCUMENTS REFERENCED HEREIN

THE REQUIREMENTS FOR ACQUIRING THE PRODUCT(S) DESCRIBED HEREIN SHALL CONSIST OF THIS SPECIFICATION SHEET AND THE ISSUE OF THE FOLLOWING SPECIFICATION LISTED IN THAT ISSUE OF THE DODISS SPECIFIED IN THE SOLICITATION NONE

THIS SPECIFICATION IS APPROVED FOR USE BY ALL DEPARTMENTS AND AGENCIES OF THE DEPARTMENT OF DEFENSE

PREPARING ACTIVITY NAVY - AS CLSTODIANS ARMY-AY NAVY AIR FORCE-99 DLA REVIEW DLR - IS USER PROJECT NUMBER 5140-1984	MILITARY SPECIFICATION SHEET TITLE HINGE, BUTT, STRUCTURAL, EXTPLEDEI	SPECIFICATION SHEET NUMBER <b>MS20001L 30 OCT 1989</b> SUPERSEDING MS20001K 30 AUG 1985 AMSC- N/A FSC - 5340
DISTRIBUTION STATEMENT A Approved for public release distribution is unlimited		Page 2 of 2